

DECOMPRESSION UNITS

SQD 117-118-119-120

DECOMPRESSION UNIT FOR HIGH PRESSURE- AND HIGH-FLOW, FOR NON-CORROSIVE GASES MODEL SQD

INDUSTRIAL GASES



Single-stage, decompression unit for centralized, high-flow systems. Provided with two cylinder connections according to standard 2-UNI11144 or 1H-11144, each one completed with on/off valve and check-valve. Using highflow rates of CO₂ and gas mixtures, preheaters up-stream the unit, are recommended.

APPLICATIONS:

- 1st stage decompression unit
- Welding and cutting machines
- Heating and thermic processes
- General industrial purposes
- SQD00118 : for gas oxygen, nitrogen, argon, carbon dioxide, mix Ar/CO₂ - Pout: max. 15 bar
- SQD00117 : for gas oxygen, nitrogen, argon, carbon dioxide, mix Ar/CO₂ - Pout: max. 50 bar
- SQD00119 : for gas Hydrogen and flammable gases- Pout: max. 15 bar
- SQD00120 : for gas Hydrogen and flammable gases - Pout: max. 50 bar

FEATURES:

Recommended for non-corrosive technical gases Wall mounting. Ready to install wall mounting panel, modular design 2 inlet port configuration 1 outlet port configuration (from the button) - 3/8" GF Rubber diaphragm.

- Maximum inlet pressure 400 bar (4.50psig);
- Tested for use with oxygen.

MATERIALS

Body, Bonnet	Brass barstock
Diaphragm	EPDM - HNBR - FPM according to the operating gases
Nozzle	Brass
Seat	PTFE FT10-02
Adjusting Knob	Brass

TECHNICAL DATA

Type	Single stage diaphragm or piston
Purity	Technical gases
Inlet pressure	Max. 300 bar (4350 psi)
Range pressure out diaphragm	1,5-15 / 5-50 bar
Flow capacity	500Nm ³ /h -
Oxygen use	Suitable

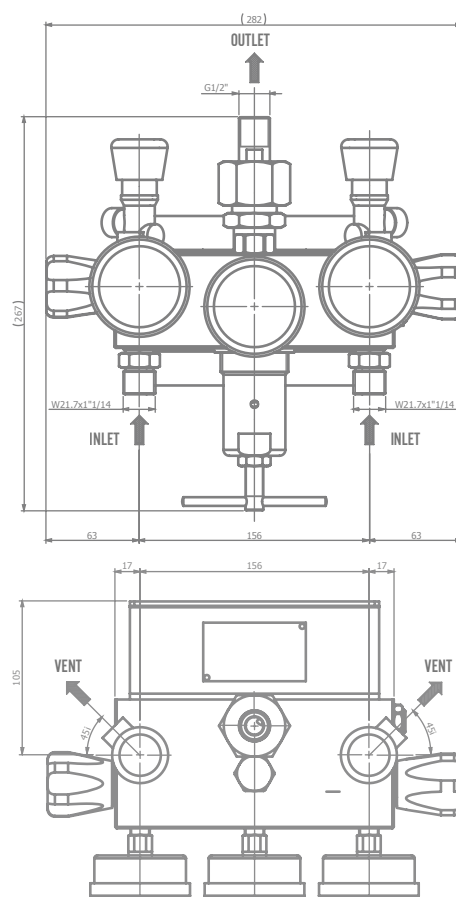
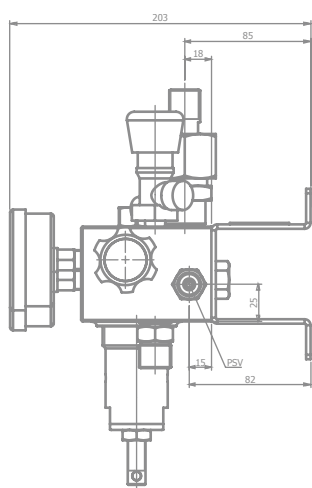

SPECIFICATIONS: For Oxygen and inert gases:

Inlet port	Nr 2 2-UNI11144 for Oxygen and inert gases
Weight	13 kg

SPECIFICATIONS: For hydrogen and flammable gases:

Inlet port	Nr 2 1H-UNI11144 for Hydrogen and flammable gases
Weight	13 kg

FLOW CHART

Diaphragm version

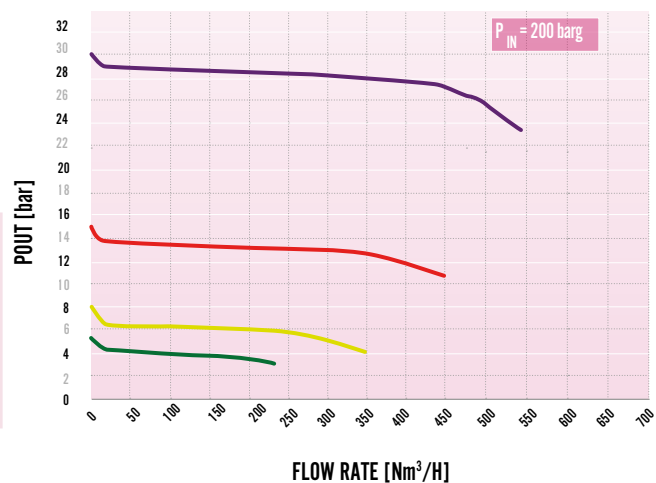

FLOW RATE

Piston version

