

## DECOMPRESSION UNITS

### ENO 20

#### DECOMPRESSION UNIT TWO-STAGE LOW PRESSURE

INDUSTRIAL  
GASES



Specially designed for oenological applications, food and even chemical industries. This unit is for blanketing tanks by inert gas, in order to prevent oxidation of the content.

Easy connection to bottle.

#### APPLICATIONS:

- Blancketing

#### FEATURES:

- Spring loaded diaphragm;
- Raccomanded for non-corrosive gases;
- Suitable for oxygen use;

#### COMPOSITION

Nr 2 Inlet valves with non-return system
Nr 1 High Pressure regulator with overpressure valve
Nr 1 Pressure regulator II° stage
Nr 1 Gauge inlet pressure
Nr 1 Gauge pressure outlet high pressure regulator
Nr 1 Gauge outlet pressure

#### TECHNICAL DATA

<b>P. max Inlet</b>	220 Bar
<b>Range pressure out</b>	15-40 mbar
<b>Materials first stage</b>	Brass / Diaphragm of NBR
<b>Materials second stage</b>	Alumuium / Diaphragm of NBR
<b>Temperature</b>	20°C to +60°C
<b>Flow</b>	60 Nm <sup>3</sup> /h a 25 mbar
<b>Inlet Connection</b>	to bottle according to 2-UNI11144
<b>Outle Connection</b>	1" GF by 3-piece connection

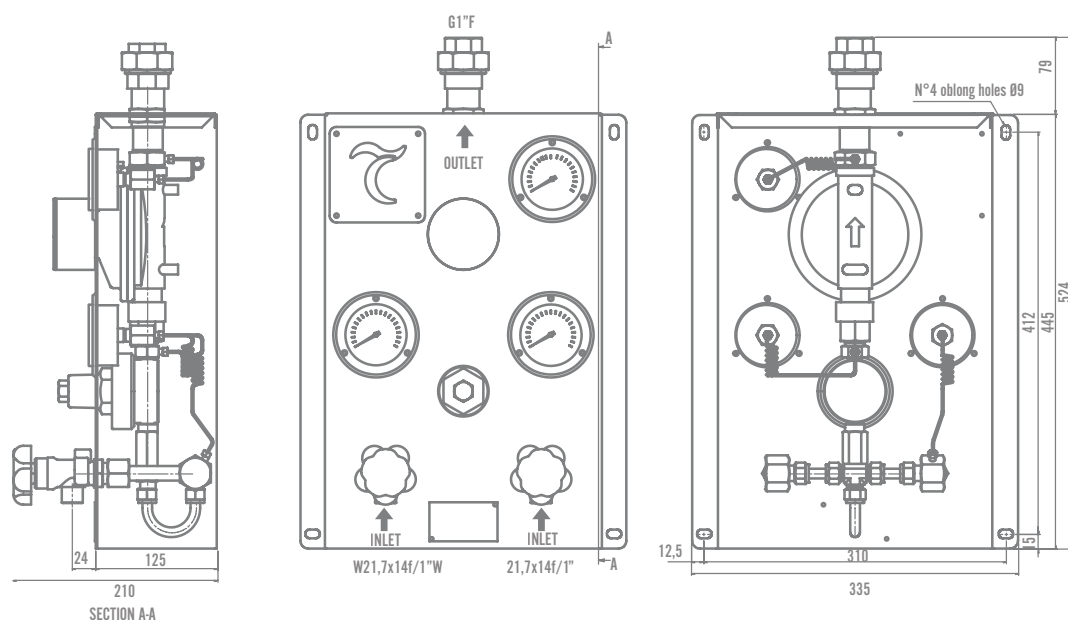

## OPTIONALS / Outlet ball valve outlet cod SVASP19

Code	Gas	Inlet Pressure	Outlet Pressure	Gauge Inlet	Gauge Outlet
SRDS02004	N2	5-UNI 11144	G 3/8" M Dx	220 bar	0,5÷10 bar

Adapter or brass comedo O2 M - N2F necessary to use the wall unit and connect through serpentine to the cylinders of various gases Cod ARC01165