

DECOMPRESSION UNITS

ENO 60

DECOMPRESSION UNIT TWO-STAGE LOW PRESSURE HIGH FLOW

INDUSTRIAL GASES



Specifically designed for oenological applications, food and even chemical industries. This unit is for blanketing tanks by inert gas, in order to prevent oxidation of the content. Easy bottle connection.

APPLICATIONS:

- Blanketing

FEATURES:

- Spring loaded diaphragm;
- Recommended for non-corrosive gases;
- Suitable for oxygen use;

MATERIALS

Body	Made of chrome-plated brass or polished Brass Cleaned and degreased for oxygen service
Panel	Anodised aluminium for wall mounting
Knobs	Plastic

TECHNICAL DATA

	Inert gases and oxygen	Inert gases and oxygen
Working pressure		Max. 250 bar
Inlet/outlet connections	Threaded W21.7 x 1/14" male, right-hand	Threaded W20 x 1/14" male, left-hand
Supplementary outlet connections		Plugged by female cup

SPECIFICATIONS

	H2-flamable gases	O2-inert gases	NH3-ammonia
Inlet port / Outlet port	W20 x 1/14"	W21,7 x 1/14"	W30 x 1/14"LH
Weight	2,1 kg for single bottle	4,2 kg for two bottles	
Temperature range		-20°C to + 110°C	-40°C/+65°C

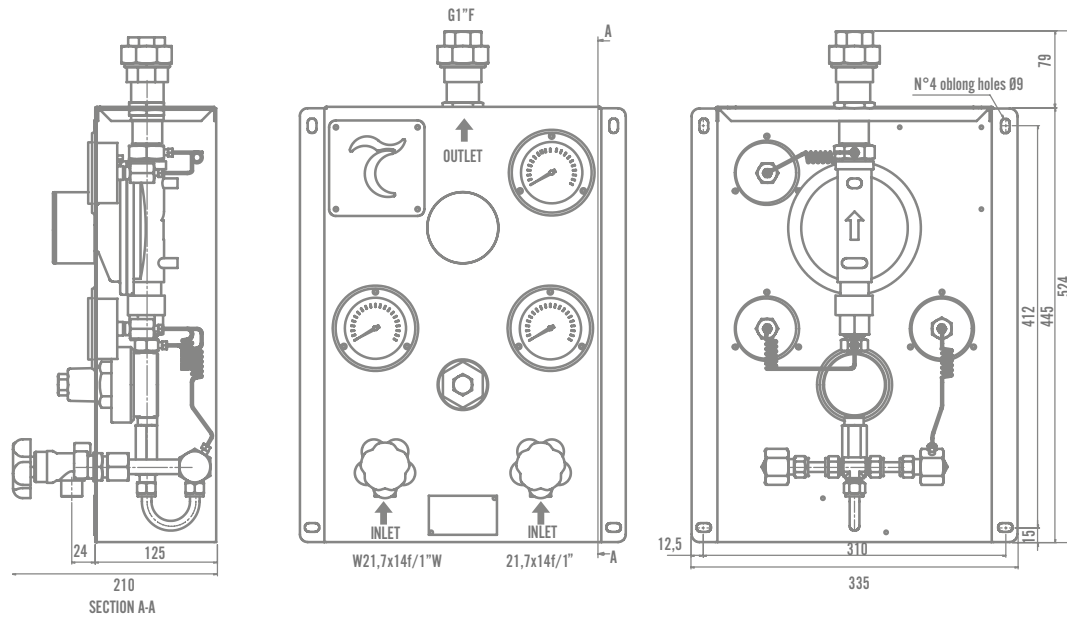

OPTIONALS :

- Hose made of copper. Available also in inox + kevlar for flexibility.

Code	Gas	Inlet Pressure	Outlet Pressure	Gauge Inlet	Gauge Outlet
SQD00110	N ₂ - Ar - CO ₂	220 bar	15-40 mbar	0÷300 bar	0÷60 bar

ACCESSORIES:

Coode	Gas	Specifications	Dimension (L)
LSC02100	N ₂	Copper chromed coil 8x4	1m
LSC02200	N ₂		2m
LSC03100	Ar		1m
LSC03200	Ar		2m

Coode	Gas	Specifications	Dimension (L)
LFG02100	N ₂	Flexible stainless steel braided hose with Kevlar and PTFE inner lining	1m
LFG02200	N ₂		2m
LFG03100	Ar		1m
LFG03200	Ar		2m