

PRESSURE REGULATORS

801 SERIES

HIGH PRESSURE REGULATOR FOR LOW FLOW

INDUSTRIAL
GASES



Brass pressure regulators for high pressure service, manufactured according to EN ISO 2503. Control system by rubber diaphragm for better stability and control. Poppet-valve (shutter) and its seat capsulated in a single element, protected by a sintered filter; this solution grants a very easy maintenance and correct functioning even in presence of impurities from the supply line.

APPLICATIONS:

- Technical applications;
- Automation;
- Industrial processes;
- Welding and laser cutting machines;
- Heating and burning systems.

FEATURES:

- Spring loaded diaphragm;
- Recommended for non-corrosive gases;
- Suitable for oxygen use;

MATERIALS

Body	Brass
Bonnet	Zamac 15 chrome-plated
Seals	PTFE
Diaphragm	Fairprene
Internal parts	Brass
Shutter	PTFE

TECHNICAL DATA

P. max Inlet	230 Bar
Range pressure out	0-1,5 / 0-4 / 0,5-10 Bar
Flow rate	100 m ³ /h
Leak rate	10 cm ³ /h secondo ISO9090 / according to ISO9090
Weight	1.8 kg / 4 lb
Working temp.	-20°C to +60°C
Conformity to Directives	ISO2503 – ISO5171

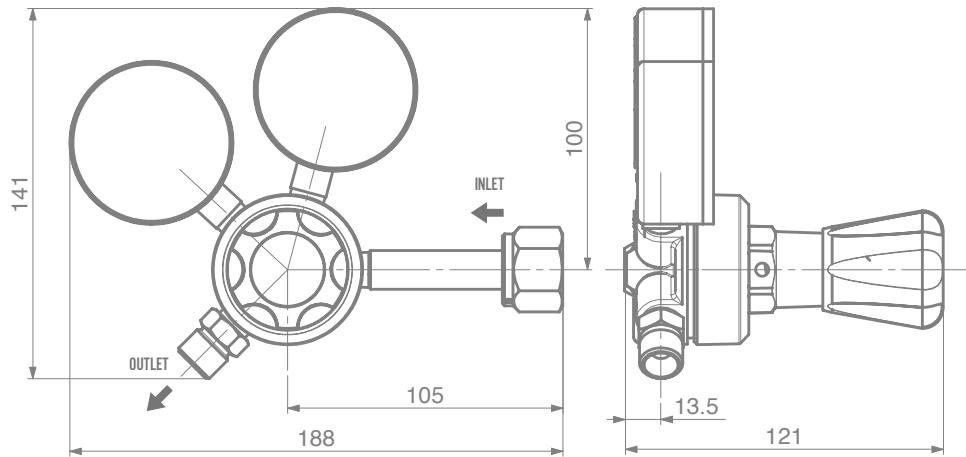

SPECIFICATIONS:

Inlet port	1/4" NPT-F - Norme UNI - NEF-DIN BS
Outlet port	3/8" BSP M or connection for plastic hoses
Weight	1,3 kg
Temperature range	-30°C to +74°C

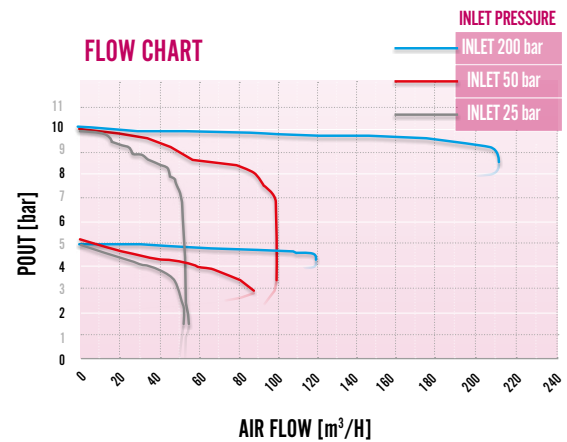
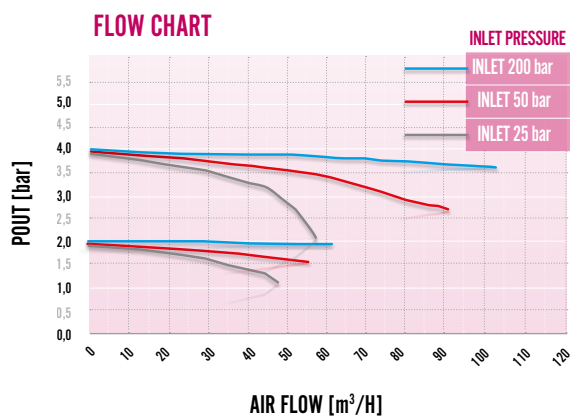

Code	Gas	Conn.Intel*	Conn.Outlet	Inlet Pressure	Outlet Pressure
SRH01010	O2 - CO2	2-UNI 11144	G 3/8" M Right	220 bar	0,5÷10 bar
SRH02010	N2	5-UNI 11144	G 3/8" M Right	220 bar	0,5÷10 bar
SRH03010	Ar - He	8-UNI 11144	G 3/8" M Right	220 bar	0,5÷10 bar
SRH06011	C2H2	7S-UNI 11144	G 3/8" M Left	25 bar	0÷1,5 bar
SRH06012	C2H2	7F-UNI 11144	G 3/8" M Left	25 bar	0÷1,5 bar
SRH07010	H2 - CH4	1H-UNI 11144	G 3/8" M Left	220 bar	0,5÷10 bar
SRH08010	GPL	1P-UNI 11144	G 3/8" M Left	25 bar	0÷4 bar

[*] Connections according to different standards are available