

GAS SUPPLY PANELS

LHPI 200P

HIGH PURITY MANUAL SWITCHOVER SUPPLY PANEL

PURE GASES



The LHPI 200P is a manual switchover high purity gas supply panel that prevents downtime by manually switching the gas supply from the primary cylinder bank to the reserve cylinder bank. The manual adjustment of the individual regulator allows to set the pressure. The system includes a purge function. Designed for applications where a slight rise in delivery pressure from full to empty cylinder can be tolerated or as first stage of pressure reduction.

APPLICATIONS:

- Laboratory pressure control;
- Research sample systems gases;
- Component testing;
- Petrochemical industry;
- Emission monitoring systems;
- Controlled atmosphere;
- Service & test equipment.

FEATURES:

- Recommended for non-corrosive gases purity levels up to grade 6.0 (99.9999);
- Wall mounting panel and brackets included;
- Ready to install wall mounting panel;
- Metal steel diaphragm eliminates contamination from diffusion or outgassing;
- Purge function and diaphragm shut-off valves for the best results;
- Possible to connect 2 gas cylinders or gas cylinder and a gas for purging operation;
- HPI 200PC - chrome plated body, bonnet and fittings;
- HPI 200PS - 316L stainless steel body, bonnet and fittings;
- 1x10⁻⁹ mbar l/s He inboard helium leak rate to maintain gas purity levels;
- Inlet / outlet - 1/4" FNPT;
- Maximum inlet pressure 300 bar (4350 psig);
- External relief valve standard;
- Tested for use with oxygen.

MATERIALS

Body, bonnet	316L stainless steel barstock LHPI 800PS or chrome plated brass barstock LHPI 200PC
Diaphragm (regulator)	Hastelloy® * C276
Diaphragm (valve)	Elgiloy®**
Nozzle	316L stainless steel
Seat	PEEK
Seals O-ring	Viton® *** (FKM)
Filter	SS 316L
Adjust. Knob	ABS plastic

* Hastelloy® is a registered trademark name of Haynes International, Inc

** Elgiloy® a registered trademark of Elgiloy Specialty Metals

*** Viton® is a registered trademark of The Chemours Company

TECHNICAL DATA

Panel type	Manual switchover supply panel
Regulator type	Single stage
Purity	Up to 6.0
Inlet pressure	Max. 300 bar (4350 psi)
Outlet pressure	2/4/10/20 bar (29/58/145/290 psi) 50/100/200 bar (720/1450/2900 psig)
Purge function	Yes
Oxygen use	Suitable

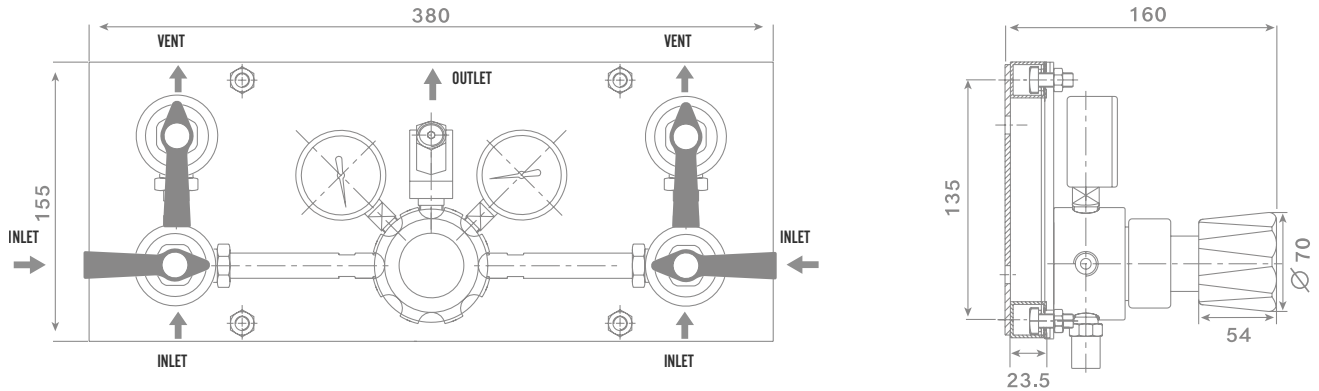

SPECIFICATIONS

Inlet / outlet ports	1/4" NPT-F
Weight	3,3 kg
Temperature range	-30°C to +74°C

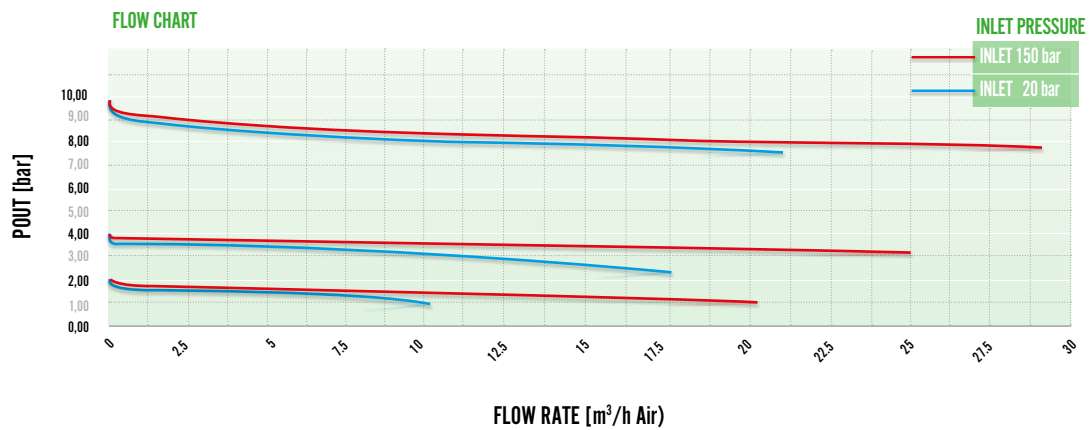

RELATED OPTIONS

- HAS - 2 - two connection
- 4 - two connection
- 6 - two connection

EXTENSIONS

