

POINT OF USE SYSTEMS

LHPI 100TP

HIGH PURITY - WALL MOUNTED POINT OF USE

PURE
GASES



The LHPT 100TP Model is a wall mounted point of use regulator available in chrome plated brass (LHPI 100TPC) or stainless steel (LHPI 100TPS) barstock for pressure control of non-corrosive gases.

APPLICATIONS:

- High purity gas applications;
- Research sample systems gases;
- Gas chromatography;
- Calibration gas;
- Process analyzer gases.

FEATURES:

- Recommended for non-corrosive gases purity levels up to grade 6.0 (99.9999);
- Wall mounting panel and brackets included;
- Ready to install wall mounting panel, modular design;
- Based on LHPI 100L regulator;
- 3 inlet port available configuration – top is standard;
- 316L stainless steel diaphragm eliminates contamination from diffusion or outgassing;
- Diaphragm inlet shut-off valves;
- Modular design;
- LHPI 100TPC - chrome plated body, bonnet and fittings;
- LHPI 100TPS - 316L stainless steel body, bonnet and fittings;
- 1x10⁻⁹ mbar l/s He inboard helium leak rate to maintain gas purity levels;
- Inlet / outlet - 1/4" FNPT;
- Maximum inlet pressure 40 bar (580 psig);
- Tested for use with oxygen.

MATERIALS

Body, bonnet	316L stainless steel barstock or chrome plated brass barstock
Diaphragm (regulator)	Hastelloy® * C276
Diaphragm (valve)	Hastelloy®*C276
Nozzle	316L stainless steel
Seat	PEEK
Seals O-ring	Viton® *** (FKM)
Filter	SS 316L
Adjust. Knob	ABS plastic

* Hastelloy® is a registered trademark name of Haynes International, Inc

*** Viton® is a registered trademark of The Chemours Company

TECHNICAL DATA

Panel type	LHPI 100L Single stage
Purity	Up to 6.0
Inlet pressure	Max. 40 bar (580 psi)
Outlet pressure	2/4/10 bar (29/58/145 psi) 20 bar (290 psi)
Flow capacity	Cv = 0,07
Oxygen use	Suitable

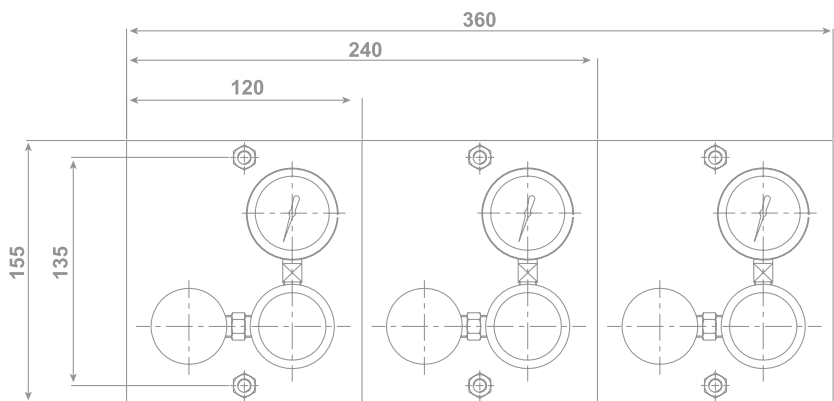

SPECIFICATIONS

Inlet / outlet ports	1/4" NPT-F
Weight	2,5 kg
Temperature range	-30°C to +74°C

