

PRESSURE REGULATORS

750 SERIES

HIGH PRESSION BRASS

INDUSTRIAL
GASES



750 series is a pressure regulator for high pressure and high flow. The peculiar characteristic of this item is the "servo-dome load technology". This execution allows a constant outlet pressure also in case of fluctuation of inlet pressure and of gas flow. Typical applications include : laser assist gases, pressure transductor, blanketing & high flow manifold.

APPLICATIONS:

- Technical applications;
- Automation;
- Industrial processes;
- Welding and laser cutting machines;
- Heating and burning systems.

FEATURES:

- Spring loaded diaphragm;
- Recommended for non-corrosive gases;
- Suitable for oxygen use;

MATERIALS

Body	Brass
Bonnet	Brass
Seals	Metal seal
Diaphragm	Neoprene + PTFE – Neoprene + PTFE
Internal parts	Brass
Shutter	PCTFE (kel-F)
Filter	Sintered bronze

TECHNICAL DATA

P. max Inlet	380 Bar
Range pressure out	1-17 / 0-35 / 0-70 Bar
Flow rate *	170 Nm ³ /h
CV	04
Connections	1/2" NPT F – 1/2" NPT F
Weight	3.9 kg / 8.6 lb

[*] See flow rate diagram

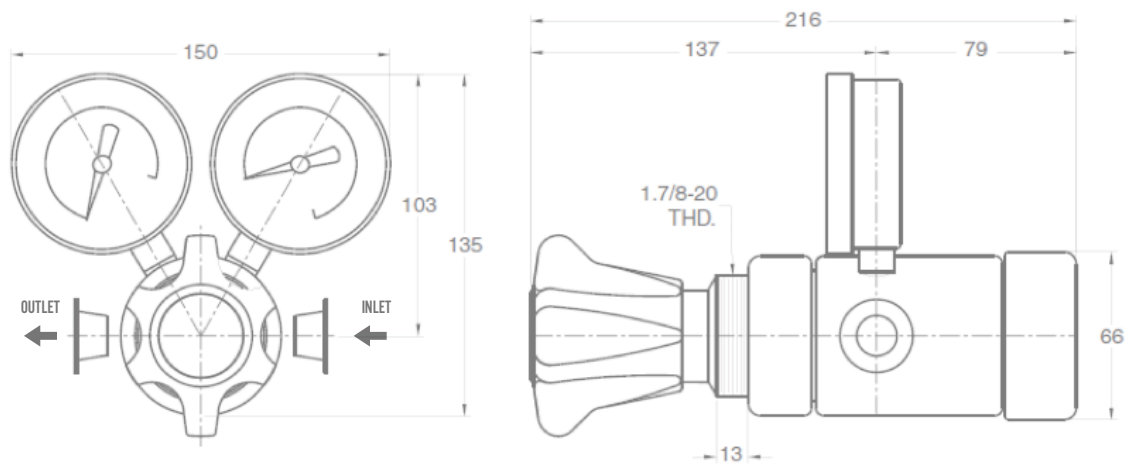

SPECIFICATIONS:

Inlet / outlet ports	1/2" NPTF - F
Weight	3,9 kg
Temperature range	-30°C to +74°C

FLOW CHART

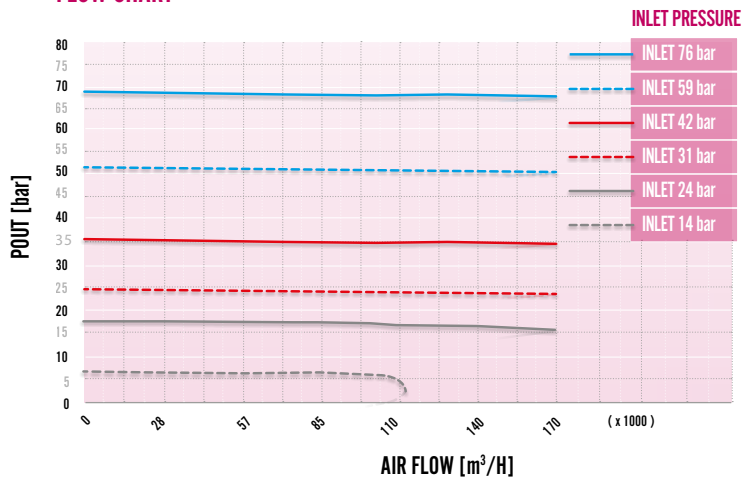

OPTIONALS/ Outlet ball valve outlet cod SVASP19:

- Kit for panel mounting
- Inlet connection for cylinder UNI or different standards
- Flanges (EN1092-1/ANSI)